

## 4-Channel ESD Array in CSP

### Features

- Four channels of ESD protection
- $\pm 15\text{kV}$  ESD protection on each channel (IEC 61000-4-2 Level 4, contact discharge)
- $\pm 30\text{kV}$  ESD protection on each channel (HBM)
- Chip Scale Package features extremely low lead inductance for optimum ESD protection
- 5-bump, 0.960mm X 1.330mm footprint
- Chip Scale Package (CSP)
- Lead-free version available

### Applications

- ESD protection for sensitive electronic equipment
- I/O port and keypad and button circuitry protection for portable devices
- Can be used for EMI filtering when combined with external series resistance
- Wireless Handsets
- Handheld PCs / PDAs
- MP3 Players
- Digital Camcorders
- Notebooks
- Desktop PCs

### Product Description

The CSPEESD304 is a quad ESD transient voltage suppression diode array. Each diode provides a very high level of protection for sensitive electronic components that may be subjected to electrostatic discharge (ESD). These diodes safely dissipate ESD strikes of  $\pm 15\text{kV}$ , exceeding the maximum requirement of the IEC 61000-4-2 international standard. Using the MIL-STD-883 (Method 3015) specification for Human Body Model (HBM) ESD, the device provides protection for contact discharges to greater than  $\pm 30\text{kV}$ .

The CSPEESD304 is particularly well-suited for portable electronics (e.g., cellular telephones, PDAs, notebook computers) because of its small package and low weight.

The CSPEESD304 is available in a space-saving, low-profile Chip Scale Package with optional lead-free finishing.

### Electrical Schematic

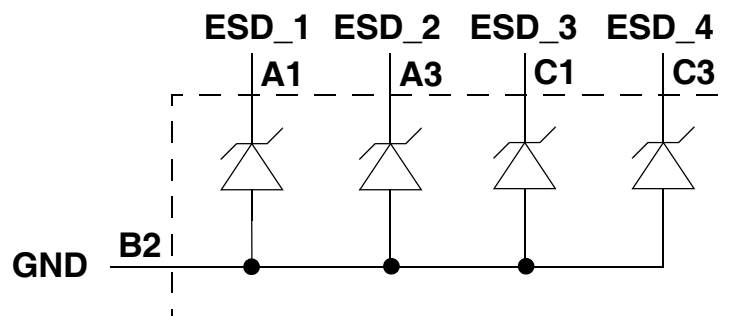

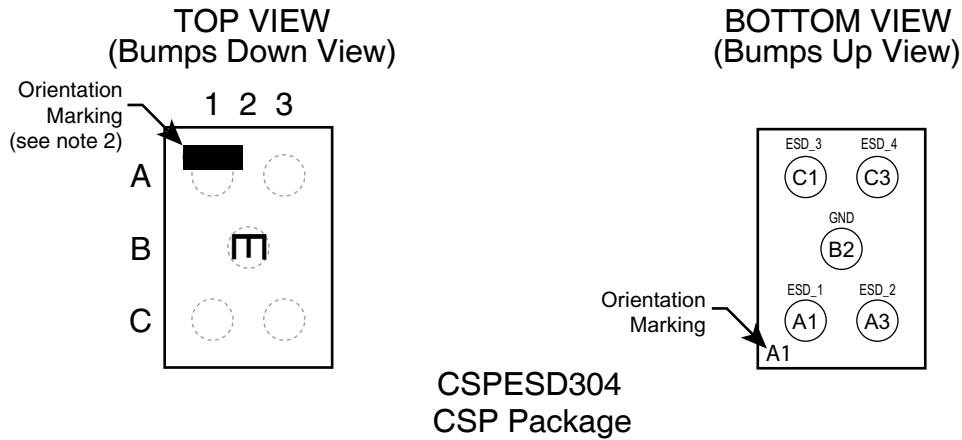
**PACKAGE / PINOUT DIAGRAMS**

**Notes:**

- 1) These drawings are not to scale.
- 2) Lead-free devices are specified by using a "+" character for the top side orientation mark.

**PIN DESCRIPTIONS**

PIN	NAME	DESCRIPTION
A1	ESD_1	ESD Channel 1
A3	ESD_2	ESD Channel 2
B2	GND	Device Ground
C1	ESD_3	ESD Channel 3
C3	ESD_4	ESD Channel 4

**Ordering Information**
**PART NUMBERING INFORMATION**

Bumps	Package	Standard Finish		Lead-free Finish <sup>2</sup>	
		Ordering Part Number <sup>1</sup>	Part Marking	Ordering Part Number <sup>1</sup>	Part Marking
5	CSP	CSPESD304	E	CSPESD304G	E

Note 1: Parts are shipped in Tape & Reel form unless otherwise specified.

Note 2: Lead-free devices are specified by using a "+" character for the top side orientation mark.

## Specifications

### ABSOLUTE MAXIMUM RATINGS

PARAMETER	RATING	UNITS
Storage Temperature Range	-65 to +150	°C
DC Package Power Rating	200	mW

### STANDARD OPERATING CONDITIONS

PARAMETER	RATING	UNITS
Operating Temperature Range	-40 to +85	°C

### ELECTRICAL OPERATING CHARACTERISTICS<sup>1</sup>

SYMBOL	PARAMETER	CONDITIONS	MIN	TYP	MAX	UNITS
V <sub>DIODE</sub>	Diode Reverse Breakdown Voltage	I <sub>DIODE</sub> = 10μA	5.5			V
I <sub>LEAK</sub>	Diode Leakage Current	V <sub>IN</sub> =3.3V, T <sub>A</sub> =25°C			100	nA
V <sub>SIG</sub>	Signal Voltage Positive Clamp Negative Clamp	I <sub>DIODE</sub> = 10mA	5.6 -0.4	6.8 -0.8	9.0 -1.5	V V
V <sub>ESD</sub>	In-system ESD Withstand Voltage a) Human Body Model, MIL-STD-883, Method 3015 b) Contact Discharge per IEC 61000-4-2	Notes 2 and 3	±30 ±15			kV kV
V <sub>CL</sub>	Clamping Voltage during ESD Discharge MIL-STD-883 (Method 3015), 8kV Positive Transients Negative Transients	Notes 2 and 3		+15 -8		V V
C <sub>DIODE</sub>	Diode Capacitance	At 2.5VDC Reverse Bias, 1MHz, 30mVAC	22	27	32	pF

Note 1: T<sub>A</sub>=-40 to +85°C unless otherwise specified.

Note 2: ESD applied to input and output pins with respect to GND, one at a time.

Note 3: These parameters are guaranteed by design and characterization.

**Performance Information**

Diode Characteristics (nominal conditions unless specified otherwise)

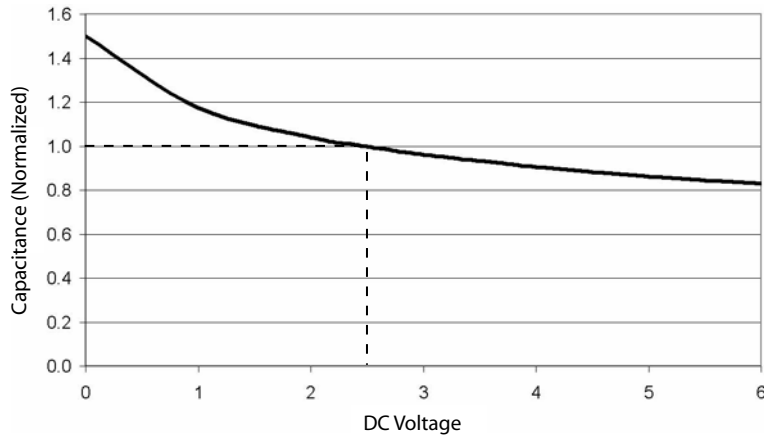

**Figure 1. Typical Diode Capacitance VS. Input Voltage (normalized to 2.5VDC)**

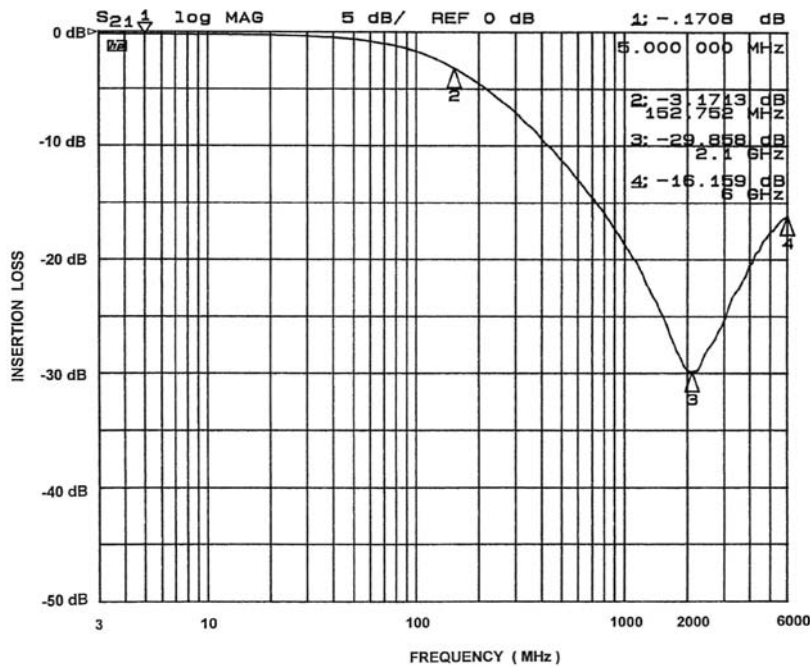

**Figure 2. Frequency Response (single channel vs. GND, in 50Ω system)**

### Application Information

Refer to Application Note AP-217, "The Chip Scale Package", for a detailed description of Chip Scale Packages offered by California Micro Devices.

PRINTED CIRCUIT BOARD RECOMMENDATIONS	
PARAMETER	VALUE
Pad Size on PCB	0.275mm
Pad Shape	Round
Pad Definition	Non-Solder Mask defined pads
Solder Mask Opening	0.325mm Round
Solder Stencil Thickness	0.125mm - 0.150mm
Solder Stencil Aperture Opening (laser cut, 5% tapered walls)	0.330mm Round
Solder Flux Ratio	50/50 by volume
Solder Paste Type	No Clean
Pad Protective Finish	OSP (Entek Cu Plus 106A)
Tolerance — Edge To Corner Ball	±50µm
Solder Ball Side Coplanarity	±20µm
Maximum Dwell Time Above Liquidous (183°C)	60 seconds
Maximum Soldering Temperature for Eutectic Devices using Eutectic Solder Paste	240°C
Maximum Soldering Temperature for Lead-free Devices using Lead-free Solder Paste	260°C

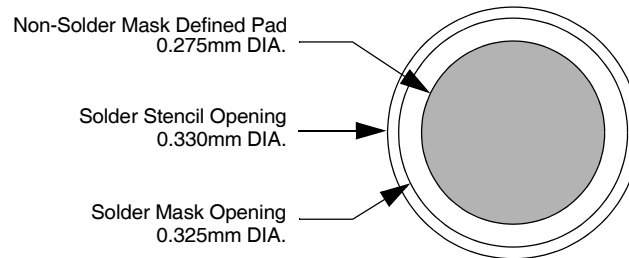

Figure 3. Recommended Non-Solder Mask Defined Pad Illustration

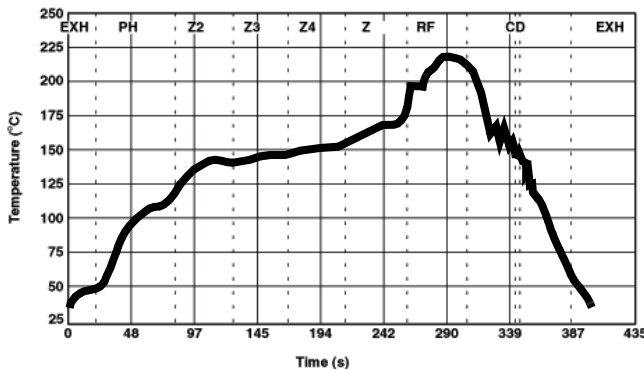

Figure 4. Eutectic (SnPb) Solder Ball Reflow Profile

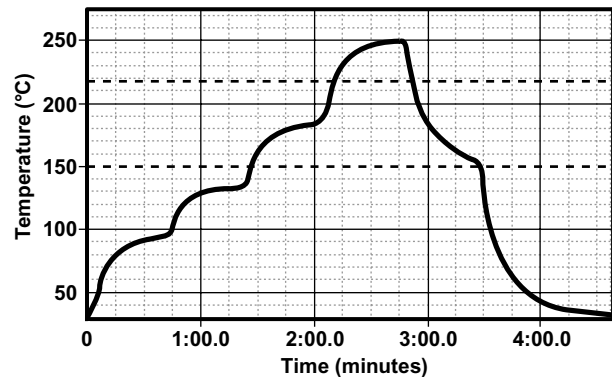

Figure 5. Lead-free (SnAgCu) Solder Ball Reflow Profile

## Mechanical Details

### CSP Mechanical Specifications

The CSPESD304 is available in a custom Chip Scale Package (CSP). Dimensions are presented below. For complete information on the CSP, see the California Micro Devices CSP Package Information document.

PACKAGE DIMENSIONS						
Package	Custom CSP					
Bumps	5					
Dim	Millimeters			Inches		
	Min	Nom	Max	Min	Nom	Max
A1	0.915	0.960	1.005	0.0360	0.0378	0.0396
A2	1.285	1.330	1.375	0.0506	0.0524	0.0541
B1	0.495	0.500	0.505	0.0195	0.0197	0.0199
B2	0.245	0.250	0.255	0.0096	0.0098	0.0100
B3	0.430	0.435	0.440	0.0169	0.0171	0.0173
B4	0.430	0.435	0.440	0.0169	0.0171	0.0173
C1	0.180	0.230	0.280	0.0071	0.0091	0.0110
C2	0.180	0.230	0.280	0.0071	0.0091	0.0110
D1	0.562	0.606	0.650	0.0221	0.0239	0.0256
D2	0.356	0.381	0.406	0.0140	0.0150	0.0160
# per tape and reel	3500 pieces					
Controlling dimension: millimeters						

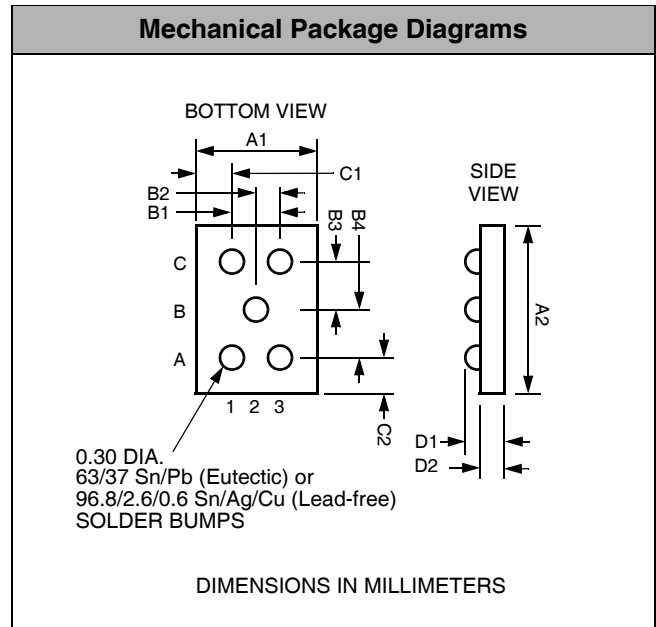

**Package Dimensions for  
CSPESD304 Chip Scale Package**

### CSP Tape and Reel Specifications

PART NUMBER	CHIP SIZE (mm)	POCKET SIZE (mm) $B_0 \times A_0 \times K_0$	TAPE WIDTH W	REEL DIAMETER	QTY PER REEL	$P_0$	$P_1$
CSPESD304	1.33 X 0.96 X 0.606	1.42 X 1.07 X 0.74	8mm	178mm (7")	3500	4mm	4mm

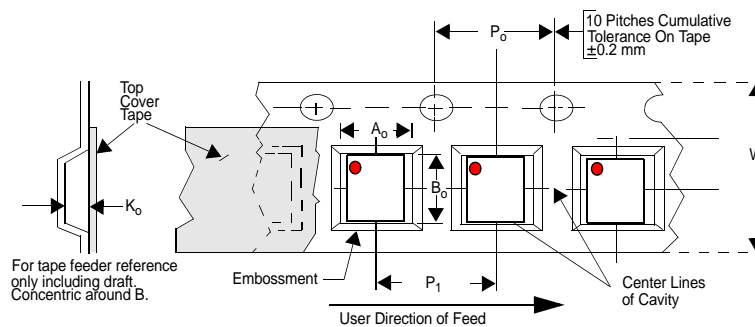

**Figure 6. Tape and Reel Mechanical Data**