

2 Channel EMI Filter with ESD Protection for Headset Microphone Applications

Features

- 2 channels of EMI filtering
- Pi-style filters in a capacitor-resistor-capacitor (C-R-C) network
- 8kV ESD protection (IEC 61000-4-2, contact discharge)
- 15kV ESD protection (HBM)
- Supports AC signals - ideal for audio applications
- Greater than 40dB of attenuation at 1GHz
- 8-lead, 2.00mm x 2.00mm footprint uDFN Package
- Low profile height of 0.5mm
- Lead-free finishing

Applications

- Headset Microphone port in mobile handsets
- I/O port protection for mobile handsets, notebook computers, PDAs etc.
- EMI filtering for data ports in cell phones, PDAs or notebook computers.

Electrical Schematic

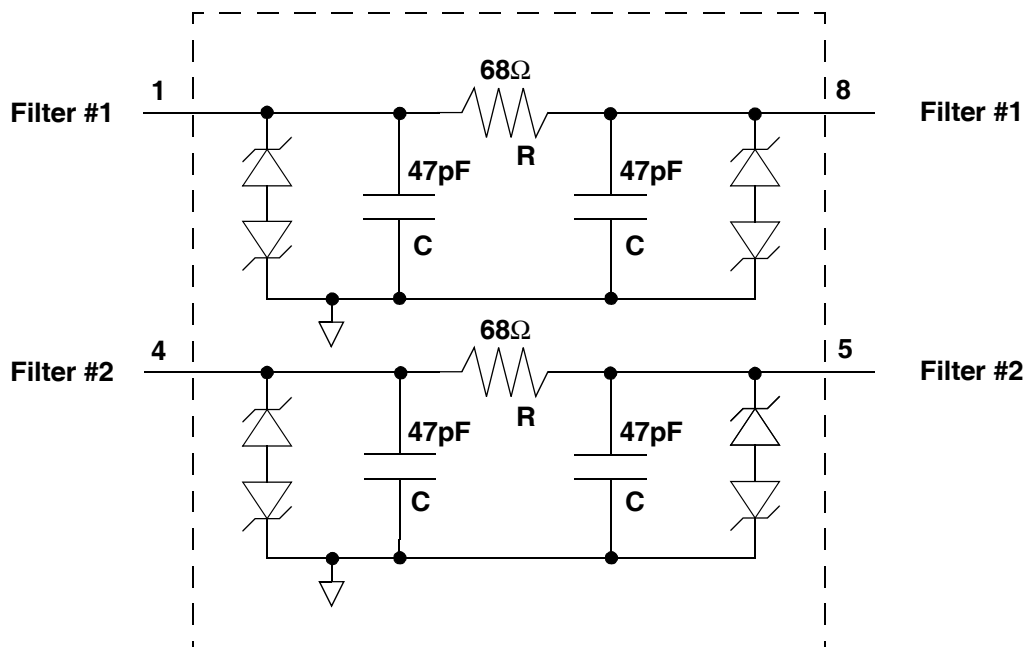

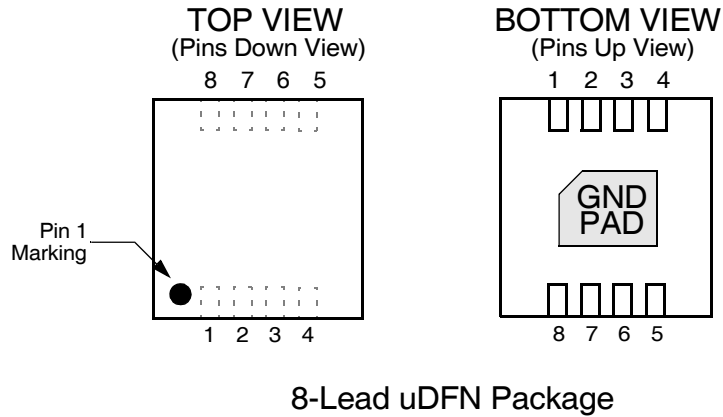
PACKAGE / PINOUT DIAGRAMS

Note: This drawing is not to scale.

PIN DESCRIPTIONS

PIN	NAME	DESCRIPTION
1	Filter #1	Filter #1
2	NC	No connect
3	NC	No connect
4	Filter #2	Filter #2
5	Filter #2	Filter #2
6	NC	No connect
7	NC	No connect
8	Filter #1	Filter #1
GND PAD	GND	Ground

Ordering Information
PART NUMBERING INFORMATION

Pins	Package	Lead-free Finish	
		Ordering Part Number ¹	Part Marking
8	uDFN	CM1682-02DE	P82

Note 1: Parts are shipped in Tape & Reel form unless otherwise specified.

Specifications

ABSOLUTE MAXIMUM RATINGS

PARAMETER	RATING	UNITS
Storage Temperature Range	-65 to +150	°C
DC package power rating	0.5	W

STANDARD OPERATING CONDITIONS

PARAMETER	RATING	UNITS
Operating Temperature Range	-40 to +85	°C

ELECTRICAL OPERATING CHARACTERISTICS (NOTE 1)

SYMBOL	PARAMETER	CONDITIONS	MIN	TYP	MAX	UNITS
R	Resistance R		61	68	75	Ω
R _{MATCH}	Resistor-to-Resistor Matching	Note 3			5	%
C _{TOT}	Total Channel Capacitance	2.5V DC; 1MHz, 30mV AC	74	94	114	pF
C	Capacitance C			47		pF
I _{LEAK}	Diode Leakage Current	V _{IN} = ±5.0V		0.1	1.0	μA
V _{SIG}	Signal Clamp Voltage Positive Clamp Negative Clamp	I _{LOAD} = 10mA I _{LOAD} = -10mA	5 -15	7 -10	15 -5	V V
V _{ESD}	In-system ESD Withstand Voltage Human Body Model, MIL-STD-883, Method 3015 Contact Discharge per IEC 61000-4-2 Level 4	Notes 2 & 3	±15 ±8			kV kV
f _C	Cut-off frequency Z _{SOURCE} = 50Ω, Z _{LOAD} = 50Ω	R = 68Ω, C = 47pF		60		MHz

Note 1: T_A = 25°C unless otherwise specified.

Note 2: ESD applied to input and output pins with respect to GND, one at a time. Clamping voltage is measured at the opposite side of the EMI filter to the ESD pin (i.e. if ESD is applied to pin 1 then clamping voltage is measured at pin 8).

Note 3: These parameters guaranteed by design and characterization.

Performance Information

Typical Filter Performance (nominal conditions unless specified otherwise, 50 ohm environment)

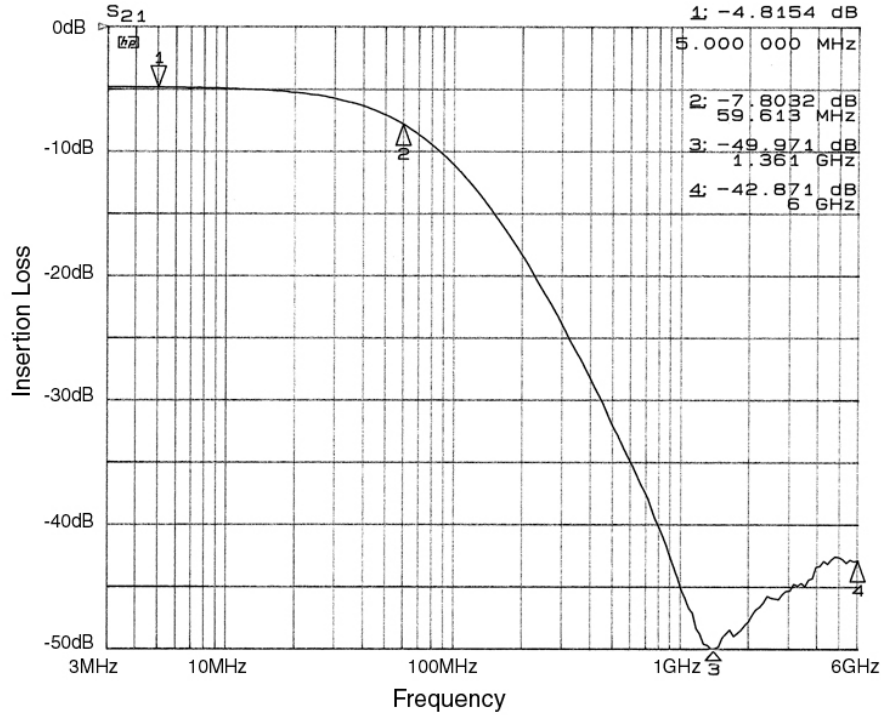

Figure 1. Insertion Loss vs. Frequency (Filter #1 to GND)

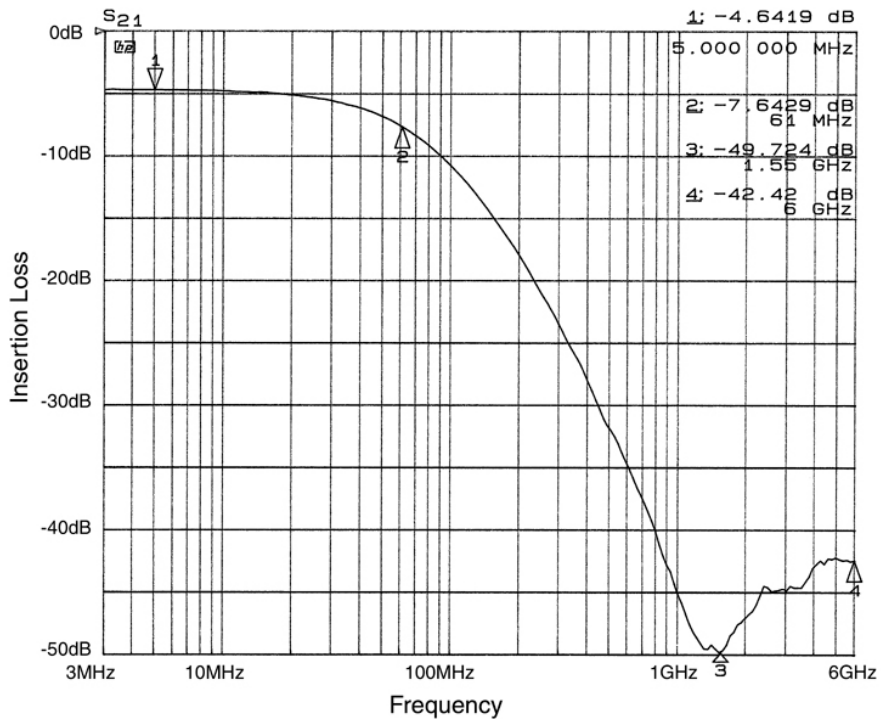

Figure 2. Insertion Loss vs. Frequency (Filter #2 to GND)

Mechanical Details

uDFN-08 Mechanical Specifications, 0.5mm

Dimensions for the CM1682 supplied in a 2mmx2mm, 8-lead, 0.5mm pitch uDFN package are presented below.

PACKAGE DIMENSIONS						
Package	uDFN					
JEDEC No.	MO-229C [†]					
Leads	8					
Dim.	Millimeters			Inches		
	Min	Nom	Max	Min	Nom	Max
A	0.45	0.50	0.55	0.018	0.020	0.022
A1	0.00	0.02	0.05	0.000	0.001	0.002
A3	0.127 REF			0.005 REF		
b	0.20	0.25	0.30	0.008	0.010	0.012
D	1.90	2.00	2.10	0.075	0.079	0.083
D2	1.50	1.60	1.70	0.059	0.063	0.067
E	1.90	2.00	2.10	0.075	0.079	0.083
E2	0.80	0.90	1.00	0.031	0.035	0.039
e	0.50 BSC			0.020 BSC		
K	0.20			0.008		
L	0.20	0.30	0.40	0.008	0.012	0.016
# per tape and reel	3000 pieces					
Controlling dimension: millimeters						

[†]This package is compliant with JEDEC standard MO-229C with the exception of the "D", "D2", "E", "E2", "K" and "L" dimensions as called out in the table above.

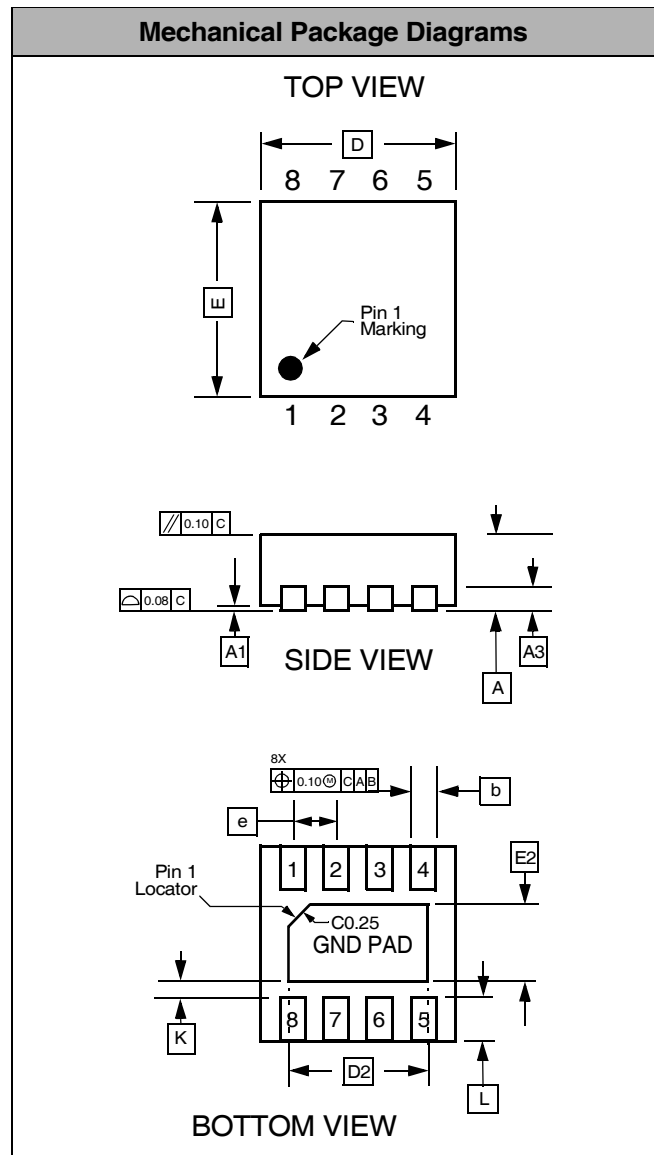

Dimensions for 8-Lead, 0.5mm Pitch uDFN Package