

4 Channel EMI Filter Array with ESD Protection

Features

- Four channels of EMI filtering with ESD protection
- Pin compatible with CMD's CSPRC032A
- Greater than 30dB attenuation over the 800MHz to 3GHz frequency range
- $\pm 15\text{kV}$ ESD protection (IEC 61000-4-2, contact discharge)
- $\pm 30\text{kV}$ ESD protection (HBM)
- 9-bump, 2.470mm x 0.970mm footprint Chip Scale Package (CSP)
- Available with *OptiGuard™* coating for improved reliability
- Lead-free versions available

Applications

- Filtering for antenna and keypad data lines
- I/O port protection for mobile handsets, notebook computers, PDAs etc.
- EMI filtering for data ports in cell phones, PDAs or notebook computers.
- EMI filtering for LCD and chip-to-chip data lines in mobile electronic devices that use flexible PCB interconnections

Product Description

CAMD's CM1425 is an EMI filter array with ESD protection, which integrates 4 pi filters (C-R-C). The CM1425 has component values of 20pF-100Ω-20pF. The parts include ESD protection diodes on every pin, which provide a very high level of protection for sensitive electronic components that may be subjected to electrostatic discharge (ESD). The ESD diodes connected to the filter ports safely dissipate ESD strikes of $\pm 15\text{kV}$, well beyond the maximum requirement of the IEC 61000-4-2 international standard. Using the MIL-STD-883 (Method 3015) specification for Human Body Model (HBM) ESD, the pins are protected for contact discharges at greater than $\pm 30\text{kV}$.

This device is particularly well-suited for portable electronics (e.g. mobile handsets, PDAs, notebook computers) because of its small package and easy-to-use pin assignments. In particular, the CM1425 is ideal for EMI filtering and protecting data lines from ESD in wireless handsets.

All CM1425 devices are optionally available with *OptiGuard™* coating which results in improved reliability at assembly. These devices are also available with standard and lead-free finishing. The CM1425 is housed in a space-saving, low-profile, chip-scale package and is fabricated with California Micro Devices' Centurion™ processes.

Electrical Schematic

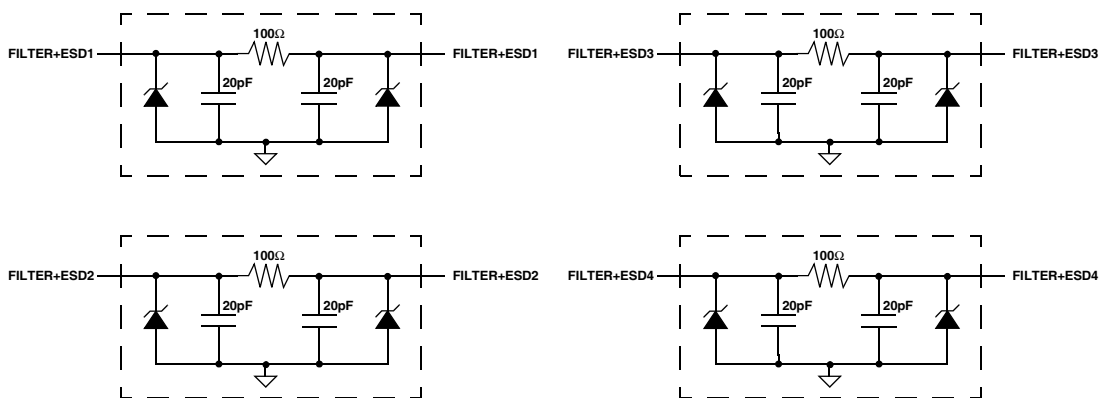

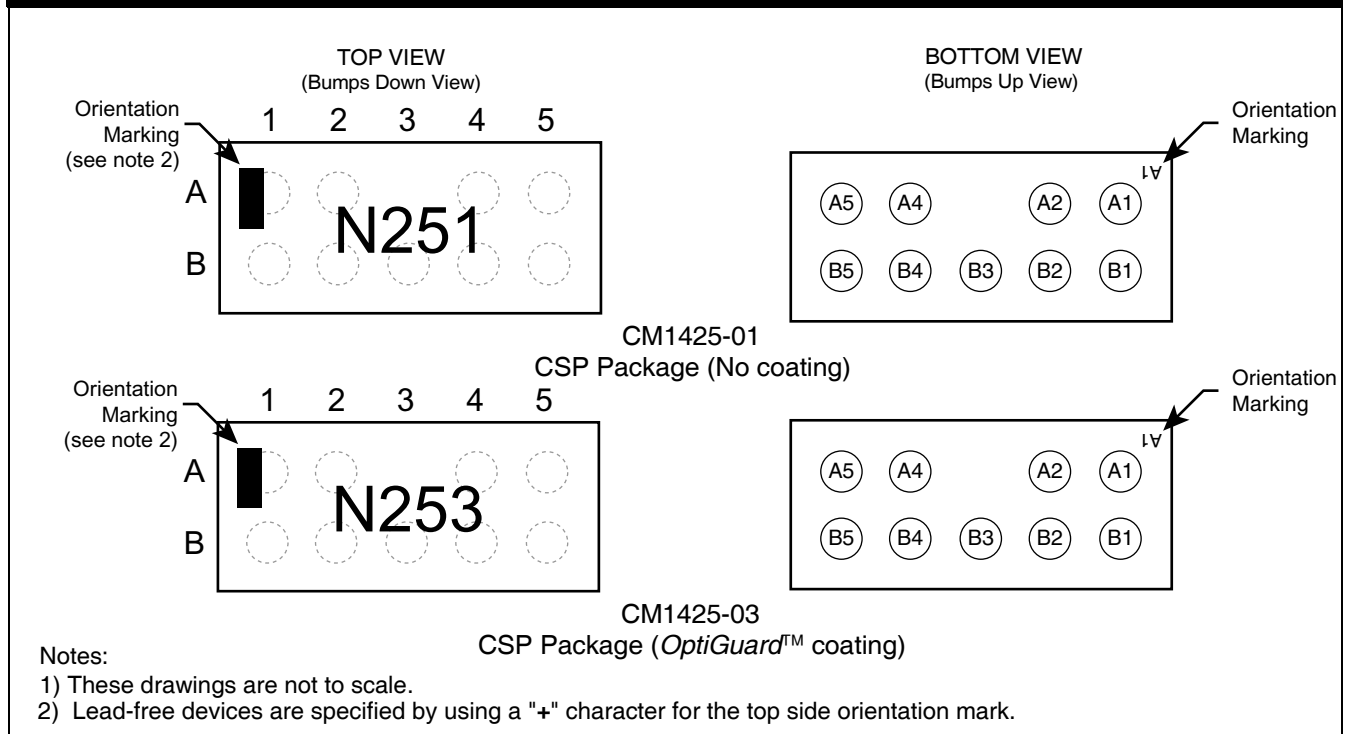
PACKAGE / PINOUT DIAGRAMS

PIN DESCRIPTIONS

PIN(s)	NAME	DESCRIPTION	PIN(s)	NAME	DESCRIPTION
A1	FILTER+ESD1	Filter Channel 1	B1	FILTER+ESD1	Filter Channel 1
A2	FILTER+ESD2	Filter Channel 2	B2	FILTER+ESD2	Filter Channel 2
A4	FILTER+ESD3	Filter Channel 3	B4	FILTER+ESD3	Filter Channel 3
A5	FILTER+ESD4	Filter Channel 4	B5	FILTER+ESD4	Filter Channel 4
B3	GND	Device Ground			

Ordering Information
PART NUMBERING INFORMATION

Bumps	PKG	Standard Finish				Lead-free Finish ²			
		No Coating		<i>OptiGuard</i> TM Coated		No Coating		<i>OptiGuard</i> TM Coated	
		Ordering Part Number ¹	Part Marking	Ordering Part Number ¹	Part Marking	Ordering Part Number ¹	Part Marking	Ordering Part Number ¹	Part Marking
9	CSP	CM1425-01CS	N251	CM1425-03CS	N253	CM1425-01CP	N251	CM1425-03CP	N253

Note 1: Parts are shipped in Tape & Reel form unless otherwise specified.

Note 2: Lead-free devices are specified by using a "+" character for the top side orientation mark.

Specifications

ABSOLUTE MAXIMUM RATINGS

PARAMETER	RATING	UNITS
Storage Temperature Range	-65 to +150	°C
Power Rating per Resistor	100	mW
Package Power Rating	300	mW

STANDARD OPERATING CONDITIONS

PARAMETER	RATING	UNITS
Operating Temperature Range	-40 to +85	°C

ELECTRICAL OPERATING CHARACTERISTICS¹

SYMBOL	PARAMETER	CONDITIONS	MIN	TYP	MAX	UNITS
R	Resistance		80	100	120	Ω
C	Capacitance	At 2.5V DC, 1MHz, 30mV AC	16	20	24	pF
V _{DIODE}	Diode Standoff Voltage	I _{DIODE} = 10μA		6.0		V
I _{LEAK}	Diode Leakage Current (reverse bias)	V _{DIODE} = + 3.3V		100	300	nA
V _{SIG}	Signal Voltage Positive Clamp Negative Clamp	I _{LOAD} = 10mA I _{LOAD} = -10mA	5.6 -1.5	6.8 -0.8	9.0 -0.4	V V
V _{ESD}	In-system ESD Withstand Voltage a) Human Body Model, MIL-STD-883, Method 3015 b) Contact Discharge per IEC 61000-4- 2 Level 4	Notes 2 and 3	±30 ±15			kV kV
R _{DYN}	Dynamic Resistance Positive Negative			1.5 0.9		Ω Ω
f _C	Cut-off Frequency Z _{SOURCE} =50Ω, Z _{LOAD} =50Ω	R = 100Ω, C = 20pF		86		MHz

Note 1: T_A=25°C unless otherwise specified.

Note 2: ESD applied to input and output pins with respect to GND, one at a time.

Note 3: These parameters are guaranteed by design and characterization.

Performance Information

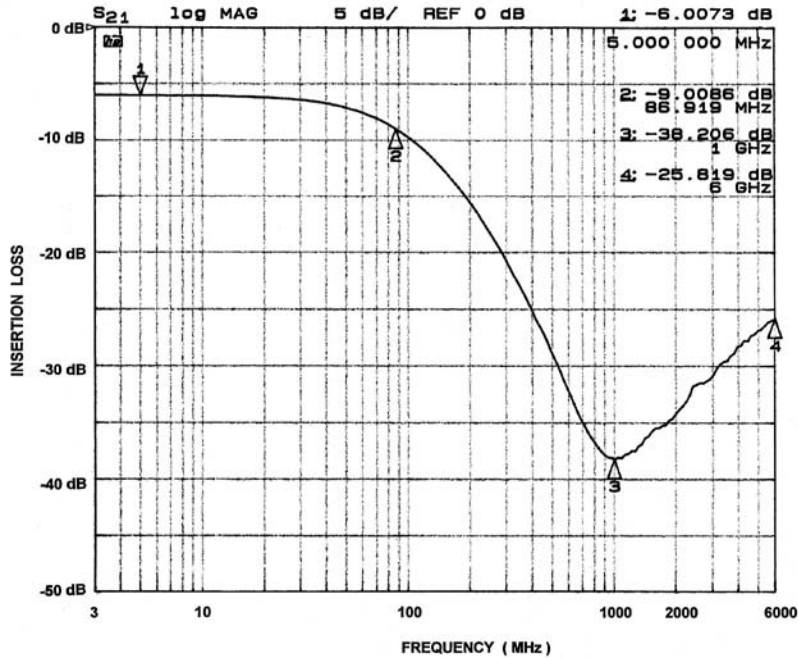

Figure 1. CM1425 Filter Typical Measured Frequency Response

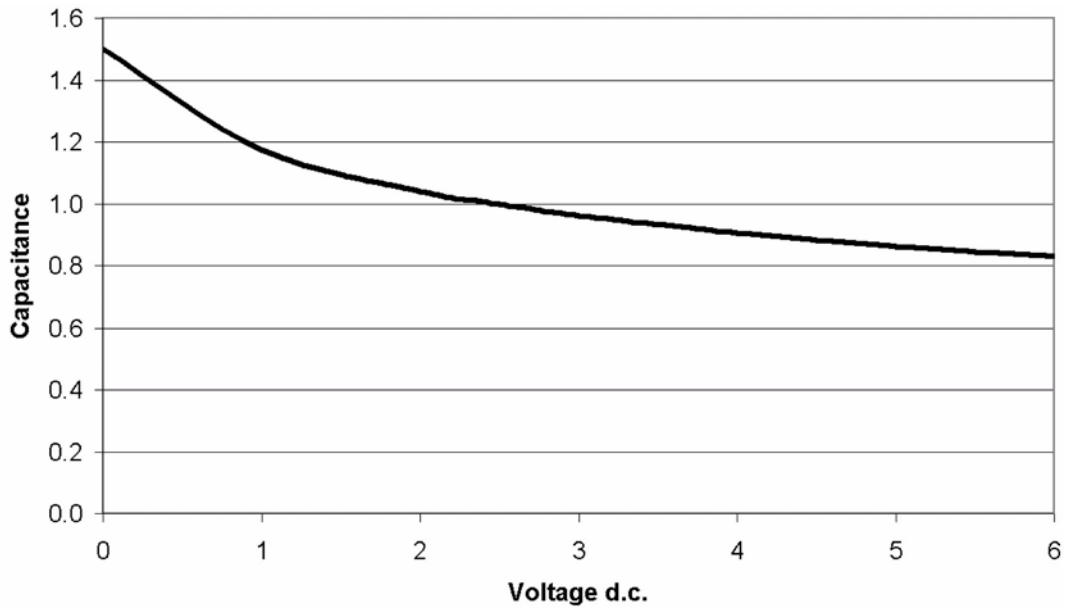

Figure 2. Filter Capacitance vs. Input Voltage over Temperature (normalized to capacitance at 2.5VDC and 25°C)

Application Information

Refer to Application Note AP-217, "The Chip Scale Package", for a detailed description of Chip Scale Packages offered by California Micro Devices.

PRINTED CIRCUIT BOARD RECOMMENDATIONS	
PARAMETER	VALUE
Pad Size on PCB	0.275mm
Pad Shape	Round
Pad Definition	Non-Solder Mask defined pads
Solder Mask Opening	0.325mm Round
Solder Stencil Thickness	0.125mm - 0.150mm
Solder Stencil Aperture Opening (laser cut, 5% tapered walls)	0.330mm Round
Solder Flux Ratio	50/50 by volume
Solder Paste Type	No Clean
Pad Protective Finish	OSP (Entek Cu Plus 106A)
Tolerance — Edge To Corner Ball	±50µm
Solder Ball Side Coplanarity	±20µm
Maximum Dwell Time Above Liquidous (183°C)	60 seconds
Maximum Soldering Temperature for a Eutectic Device using Eutectic Solder Paste	240°C
Maximum Soldering Temperature for a Lead-free Device using Lead-free Solder Paste	260°C

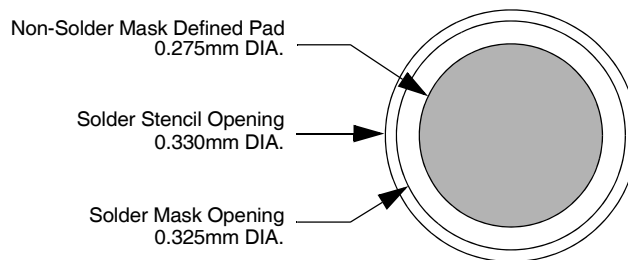

Figure 3. Recommended Non-Solder Mask Defined Pad Illustration

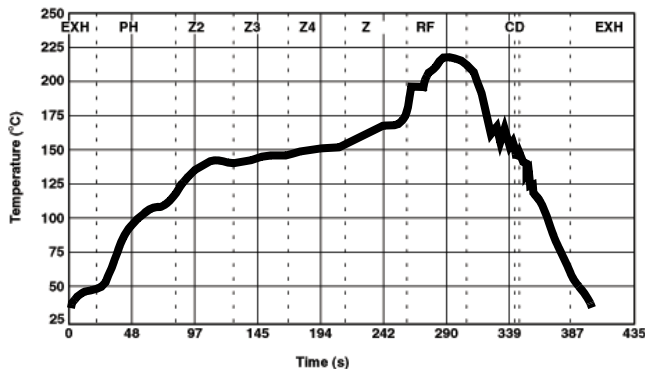

Figure 4. Eutectic (SnPb) Solder Ball Reflow Profile

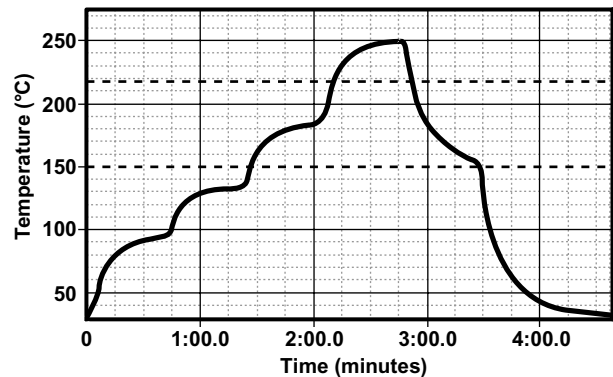

Figure 5. Lead-free (SnAgCu) Solder Ball Reflow Profile

Mechanical Details

CM1425 devices are packaged in a custom Chip Scale Packages (CSP) and available with optional *OptiGuard™* coating.

CM1425 9-bump CSP Mechanical Specifications

The CM1425 devices are packaged in a 9-bump custom Chip Scale Package (CSP). Dimensions are presented below.

PACKAGE DIMENSIONS						
Package	Custom CSP					
Bumps	9					
Dim	Millimeters			Inches		
	Min	Nom	Max	Min	Nom	Max
A1	0.925	0.970	1.015	0.0364	0.0382	0.0400
A2	2.425	2.470	2.515	0.0955	0.0972	0.0990
B1	0.495	0.500	0.505	0.0195	0.0197	0.0199
B2	0.495	0.500	0.505	0.0195	0.0197	0.0199
C1	0.185	0.235	0.285	0.0073	0.0093	0.0112
C2	0.185	0.235	0.285	0.0073	0.0093	0.0112
D1 ¹	0.562	0.606	0.650	0.0221	0.0239	0.0256
D2 ¹	0.356	0.381	0.406	0.0140	0.0150	0.0160
D3 ²	0.575	0.644	0.714	0.0226	0.0254	0.0281
D4 ²	0.368	0.419	0.470	0.0145	0.0165	0.0185
# per tape and reel	3500 pieces					
Controlling dimension: millimeters						

Note 1: Applies to uncoated devices only.

Note 2: Applies to *OptiGuard™* (coated) devices only.

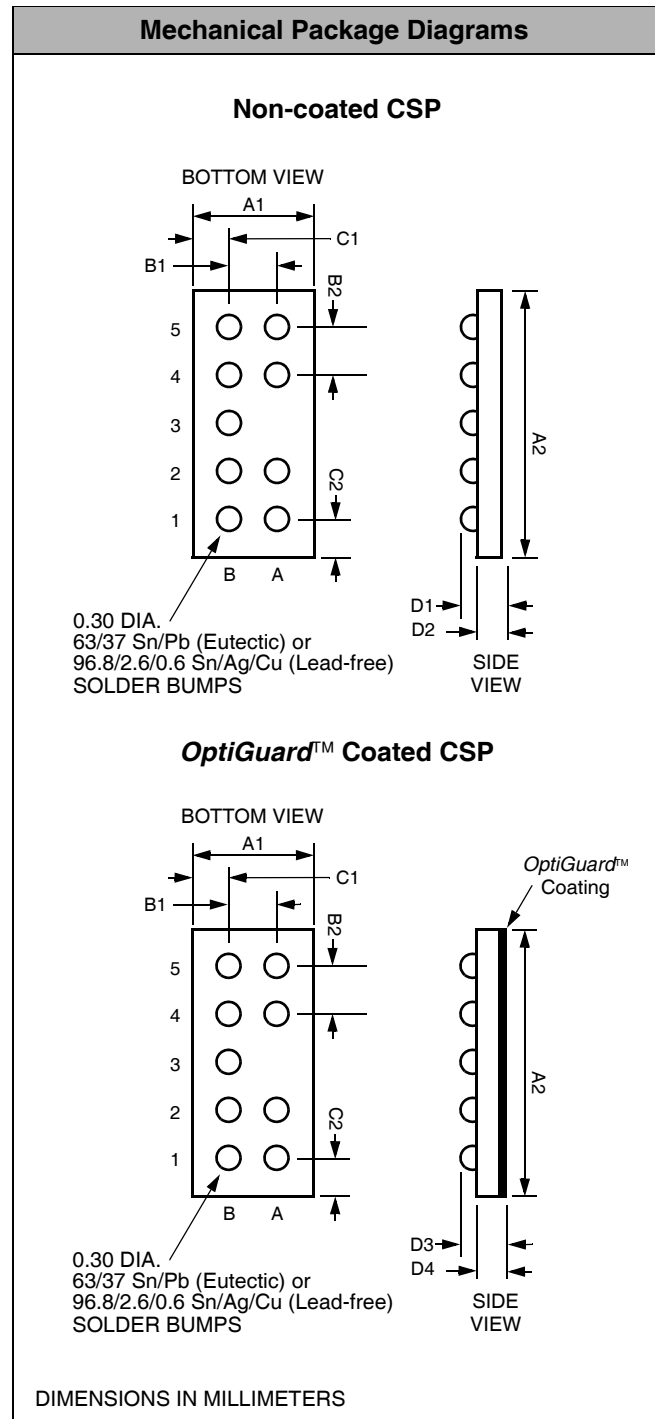

**Package Dimensions
CM1425 9-bump Chip Scale Package**

Mechanical Details (cont'd)

CSP Tape and Reel Specifications

PART NUMBER	PKG. SIZE (mm)	POCKET SIZE (mm) $B_0 \times A_0 \times K_0$	TAPE WIDTH W	REEL DIA.	QTY PER REEL	P_0	P_1
CM1425-01	2.470 X 0.970 X 0.606	2.62 X 1.12 X 0.762	8mm	178mm (7")	3500	4mm	4mm
CM1425-03	2.470 X 0.970 X 0.644	2.62 X 1.12 X 0.762	8mm	178mm (7")	3500	4mm	4mm

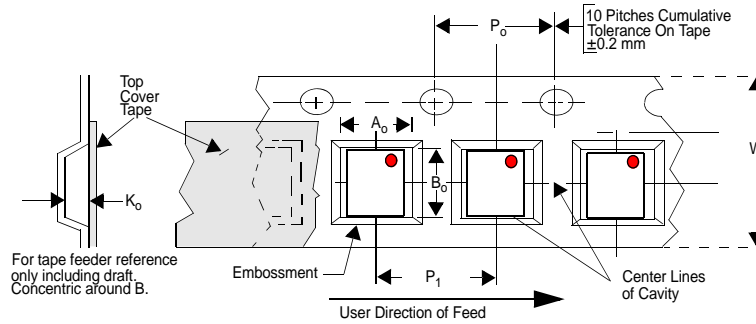

Figure 6. Tape and Reel Mechanical Data