

Praetorian™ L-C EMI Filter with ESD Protection for Headset Speaker Applications

Features

- 2 channels of EMI filtering
- $\pm 30\text{kV}$ ESD protection (IEC 61000-4-2, contact discharge)
- $\pm 30\text{kV}$ ESD protection (HBM)
- *OptiGuard*™ coating for improved reliability at assembly
- Greater than 30dB of attenuation at 1GHz
- 5-bump, 1.590mm x 1.220mm footprint Chip Scale Package (CSP)
- RoHS-compliant, lead-free packaging

Applications

- Headset speaker port in mobile handsets
- I/O port protection for mobile handsets, notebook computers, PDAs etc.
- EMI filtering for data ports in cell phones, PDAs or notebook computers.

Product Description

California Micro Devices' CM1419 is an L-C EMI filter array with ESD protection, which integrates two Pi-filters (C-L-C) for the headset speaker. The CM1419 has component values of 117pF-3.0nH-117pF. The parts include ESD protection diodes on all input/output pins, that provide a very high level of protection for sensitive electronic components against possible electrostatic discharge (ESD). The ESD diodes connected to the filter ports safely dissipate ESD strikes of $\pm 30\text{kV}$, beyond the maximum requirement of the IEC61000-4-2 international standard. In accordance with MIL-STD-883 (Method 3015) specification for Human Body Model (HBM) ESD, the pins are protected for contact discharges at greater than $\pm 30\text{kV}$.

This device is particularly well suited for portable electronics (e.g. mobile handsets, PDAs, notebook computers) because of its small package format and easy-to-use pin assignments. In particular, the CM1419 is ideal for EMI filtering and protecting speaker output lines of the headset speaker from ESD in mobile handsets. Most speakers have an impedance of 8Ω . However, to maximize the power output, the resistance of an EMI filter needs to be as low as possible. The CM1419 addresses this by using a C-L-C based EMI filter with an inductor having less than 0.35Ω of resistance.

The CM1419 comes with *OptiGuard*™ coating resulting in improved reliability at assembly. The CM1419 is housed in a space saving, low profile Chip Scale Package with RoHS-compliant, lead-free finishing.

Electrical Schematic

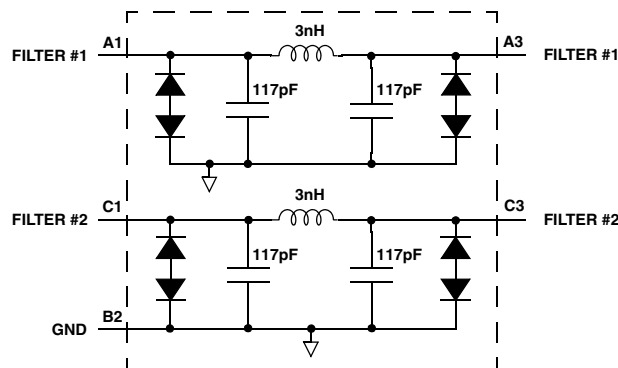

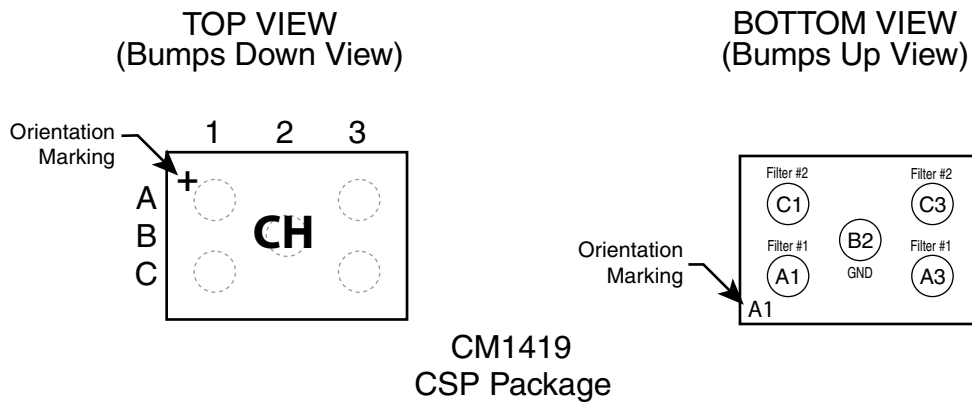
PACKAGE / PINOUT DIAGRAMS

Notes:

1) These drawings are not to scale.

PIN DESCRIPTIONS

PIN	NAME	DESCRIPTION
A1	Filter #1	Filter #1 Input
A3	Filter #1	Filter #1 Input
C1	Filter #2	Filter #2 Input
C3	Filter #2	Filter #2 Input
B2	GND	Device Ground

Ordering Information
PART NUMBERING INFORMATION

Pins	Package	Lead-free Finish ²	
		Ordering Part Number ¹	Part Marking
5	CSP	CM1419-02CP	CH

Note 1: Parts are shipped in Tape and Reel form unless otherwise specified.

Specifications

ABSOLUTE MAXIMUM RATINGS

PARAMETER	RATING	UNITS
Storage Temperature Range	-65 to +150	°C
DC Current per Inductor	30	mA
DC Package Power Rating	0.5	W

STANDARD OPERATING CONDITIONS

PARAMETER	RATING	UNITS
Operating Temperature Range	-40 to +85	°C

ELECTRICAL OPERATING CHARACTERISTICS (SEE NOTE 1)

SYMBOL	PARAMETER	CONDITIONS	MIN	TYP	MAX	UNITS
L	Inductance			3.0		nH
R	DC Channel Resistance			0.28	0.35	Ω
C _{TOT}	Total Channel Capacitance	2.5V dc; 1MHz, 30mV ac	187	234	281	pF
C ₁	Capacitance C ₁	2.5V dc; 1MHz, 30mV ac	93	117	140	pF
V _{ST}	Stand-off Voltage	I = 10μA		6.0		V
I _{LEAK}	Diode Leakage Current	V _{IN} = ±3.3V		0.1	1.0	μA
V _{SIG}	Signal Clamp Voltage Positive Clamp Negative Clamp	I _{LOAD} = 10mA I _{LOAD} = -10mA	5.6 -9.0	6.8 -6.8	9.0 -5.6	V V
V _{ESD}	In-system ESD Withstand Voltage a) Human Body Model, MIL-STD-883, Method 3015 b) Contact Discharge per IEC 61000-4-2 Level 4	Notes 2 and 3	±30 ±30			kV kV
R _{DYN}	Dynamic Resistance Positive Negative			0.95 0.90		Ω Ω
f _C	Cut-off frequency Z _{SOURCE} = 50Ω, Z _{LOAD} = 50Ω	L = 3nH, C = 117pF		22		MHz

Note 1: T_A=25°C unless otherwise specified.

Note 2: ESD applied to input and output pins with respect to GND, one at a time.

Note 3: These parameters are guaranteed by design and characterization.

Performance Information

Typical Filter Performance (nominal conditions unless specified otherwise, 50 Ohm Environment)

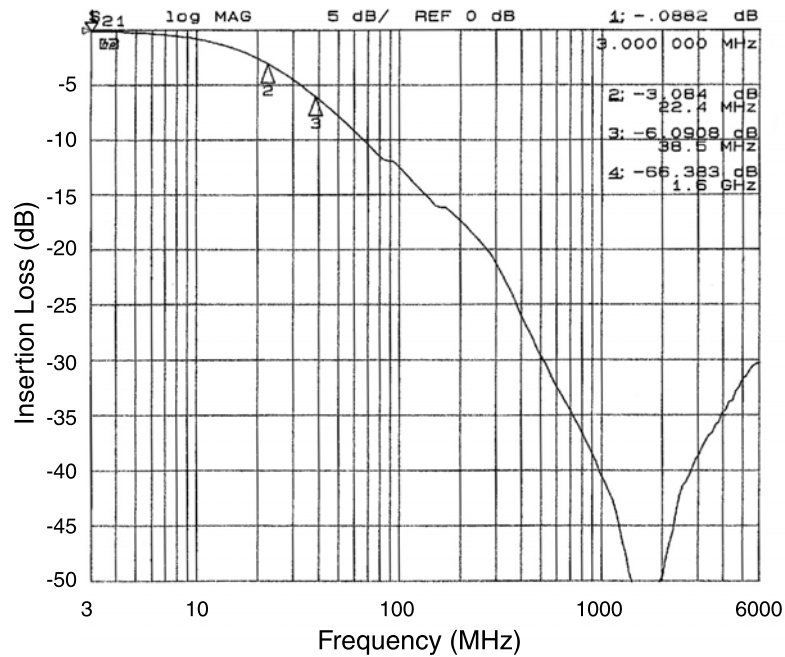

Figure 1. Insertion Loss vs. Frequency (Filter #1 to GND B2)

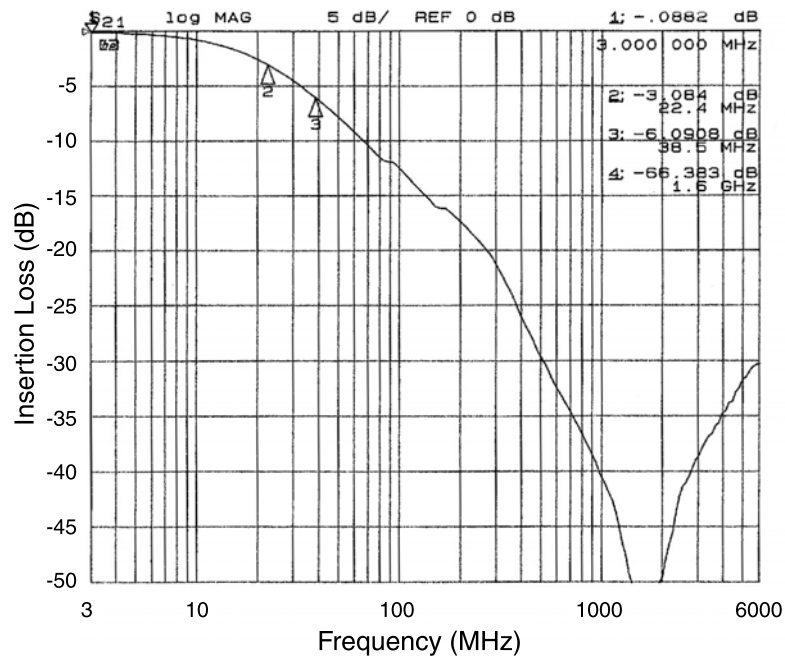

Figure 2. Insertion Loss vs. Frequency (Filter #2 to GND B2)

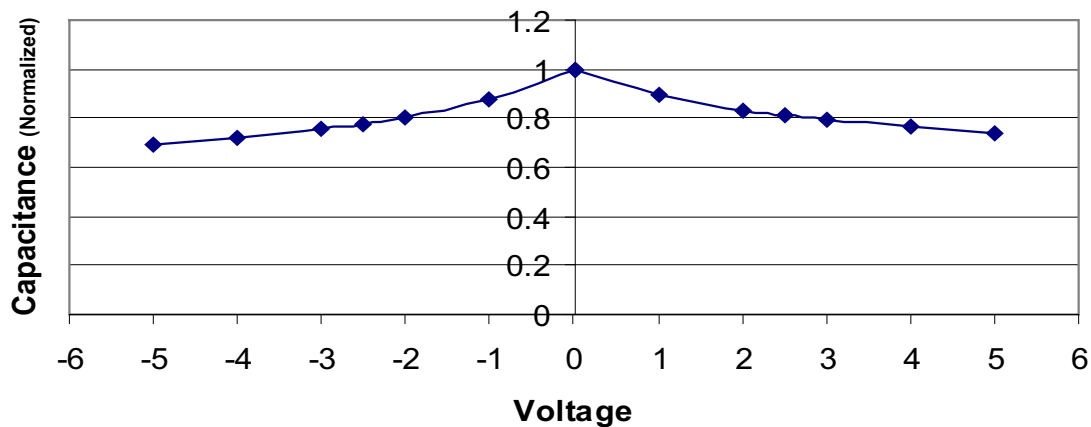

Figure 3. Typical Diode Capacitance vs. Input Voltage (normalized to 2.5V d.c.)

Application Information

Refer to Application Note AP-217, "The Chip Scale Package", for a detailed description of Chip Scale Packages offered by California Micro Devices.

PRINTED CIRCUIT BOARD RECOMMENDATIONS

PARAMETER	VALUE
Pad Size on PCB	0.275mm
Pad Shape	Round
Pad Definition	Non-Solder Mask defined pads
Solder Mask Opening	0.325mm Round
Solder Stencil Thickness	0.125 - 0.150mm
Solder Stencil Aperture Opening (laser cut, 5% tapered walls)	0.330mm Round
Solder Flux Ratio	50/50 by volume
Solder Paste Type	No Clean
Pad Protective Finish	OSP (Entek Cu Plus 106A)
Tolerance — Edge To Corner Ball	±50µm
Solder Ball Side Coplanarity	±20µm
Maximum Dwell Time Above Liquidous	60 seconds
Maximum Soldering Temperature for Lead-free Devices using a Lead-free Solder Paste	260°C

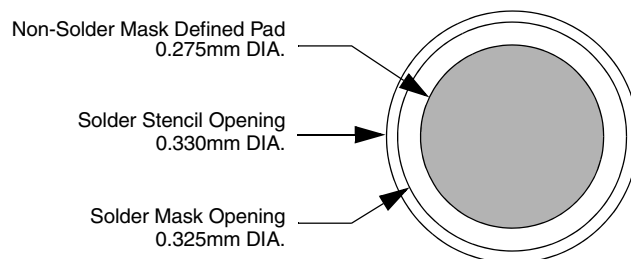

Figure 4. Recommended Non-Solder Mask Defined Pad Illustration

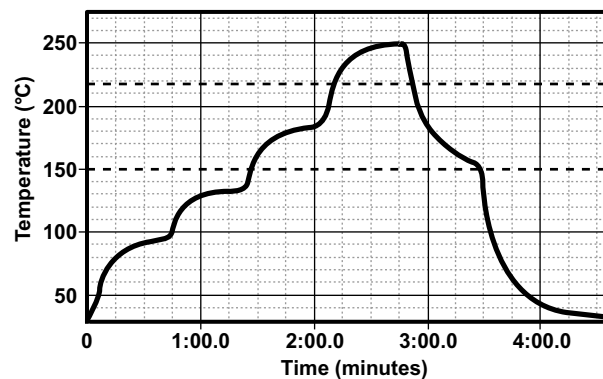

Figure 5. Lead-free (SnAgCu) Solder Ball Reflow Profile

Mechanical Details

CM1419 CSP Mechanical Specifications

The CM1419 is supplied in 5-bump Chip Scale Package (CSP). Dimensions are presented below.

PACKAGE DIMENSIONS						
Package	Custom CSP					
Bumps	5					
Dim	Millimeters			Inches		
	Min	Nom	Max	Min	Nom	Max
A1	1.175	1.220	1.265	0.0463	0.0480	0.0498
A2	1.545	1.590	1.635	0.0608	0.0626	0.0644
B1	0.495	0.500	0.505	0.0195	0.0197	0.0199
B2	0.245	0.250	0.255	0.0096	0.0098	0.0100
B3	0.430	0.435	0.440	0.0169	0.0171	0.0173
C1	0.310	0.360	0.410	0.0122	0.042	0.0161
C2	0.310	0.360	0.410	0.0122	0.042	0.0161
D1	0.575	0.644	0.714	0.0226	0.0254	0.0281
D2	0.368	0.419	0.470	0.0145	0.0165	0.0185
# per tape and reel	3500 pieces					
Controlling dimension: millimeters						

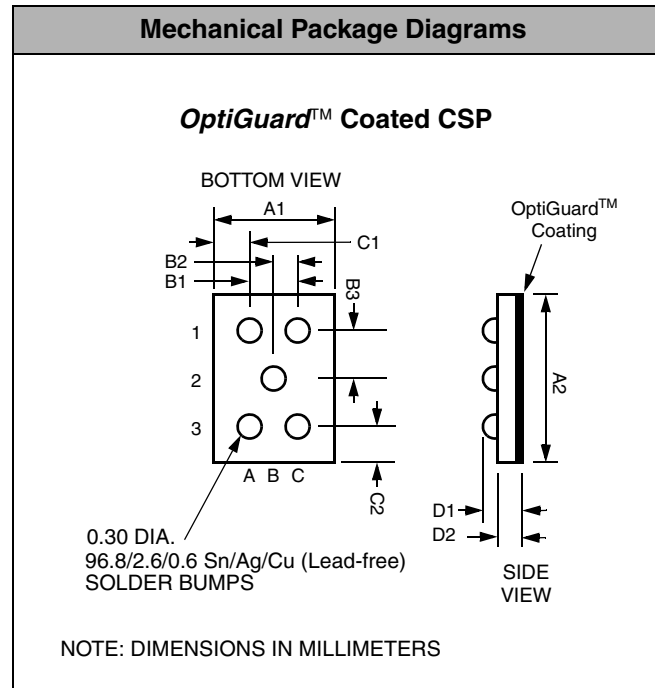

**Package Dimensions for CM1419-02CP
5-bump Chip Scale Package**

Mechanical Details (cont'd)

CSP Tape and Reel Specifications

PART NUMBER	CHIP SIZE (mm)	POCKET SIZE (mm) $B_0 \times A_0 \times K_0$	TAPE WIDTH W	REEL DIA.	QTY PER REEL	P_0	P_1
CM1419-02CS/CP	1.59 X 1.22 X 0.64	1.78 x 1.38 x 0.76	8mm	178mm (7")	3500	4mm	4mm

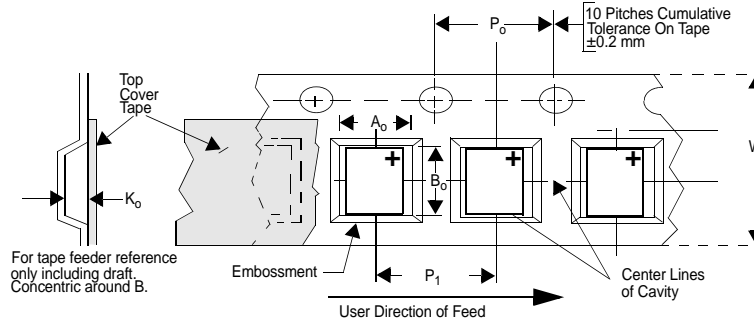

Figure 6. Tape and Reel Mechanical Data