



White Paper

FlexBoost™ Technology

**A Breakthrough Concept in the Battle for
Efficiency in Mobile Handset Applications**

FLEXBOOST™

FlexBoost™ Technology: A Breakthrough Concept in the Battle for Efficiency in Mobile Handset Applications

Overview

Increasing need for power in mobile handset applications

With increasing demand for advanced multimedia capabilities, higher resolution displays and camera modules, the system characteristics of mobile handset applications have evolved tremendously over the past few years. One direct consequence is the significant increase in power budget required by the display and overall system. In parallel, Li-Ion battery technology is improving but not at the same pace as the increase in advanced multimedia capabilities. Therefore, the pressure to optimize individual modules and integrated circuits from a power consumption standpoint is tremendous. The following figure illustrates qualitatively the challenge the industry is facing from a power management standpoint.

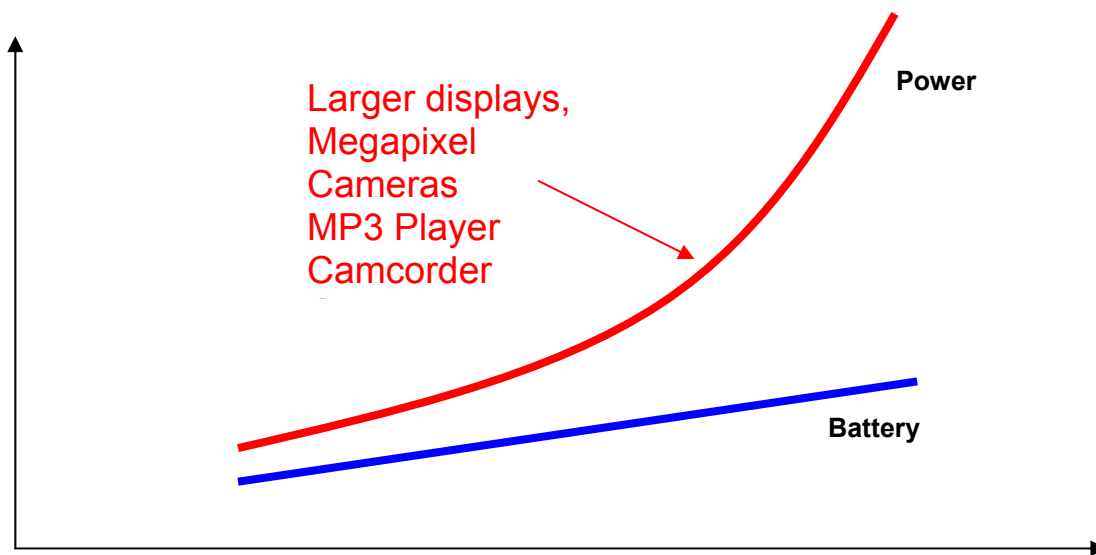

As part of the overall power budget of the cell phone, besides communication ICs such as power amplifier, the most demanding sub-systems are:

- Display(s) backlight
- Camera flash
- Various indicators or funlights

As resolutions increase drastically, these features require the use of more and more LEDs and higher current rates

Increasingly popular use cases for cell phones challenge the battery as they require a bright and large display for potentially long periods of time:

- Picture Point & Shoot
- Picture Viewing
- Camera Preview

- Camcorder functions
- Gaming

But, no matter the application, the one cell Li-Ion battery is still the most popular power provider for handset equipment due to its competitive performance.

Ultimately, the LED sub-systems (backlight, flash....) represent a significant part of the power budget of an advanced wireless handset. Therefore, serious attention is needed to optimize the driving scheme by maximizing its efficiency.

Existing Inductor Boost Architecture and its Limitations

Space being another significant constraint for wireless handset designers, the LED driver needs to be as compact as possible. Therefore, it makes sense to consider driving as many LEDs as possible from the same IC. When considering an inductor boost architecture, several outputs can be assigned to driving several strings of LEDs. One output could be driving the main display backlight LEDs, another the camera flash LED or keypad LEDs. In most cases, each string would feature a different load or different number of LEDs (therefore different voltage requirements). Solutions currently available in the market would drive all outputs at the same voltage, which obviously translates into a significant loss in terms of efficiency.

FlexBoost™ Architecture and its Benefits

California Micro Devices (CMD) announced FlexBoost™, a breakthrough inductor boost concept and architecture to efficiently support asymmetrical schemes. When driving the primary display backlight and a sub-display backlight as well as a camera flash LED or keypad LEDs, it is quite common to have to deal with asymmetrical loading on various strings. For instance, 5 white LEDs are used for a large resolution display backlight and potentially one to three to enable the camera flash. Solutions available today typically output the same voltage on all strings, which results in significant degradation of overall efficiency. FlexBoost™ allows output of the appropriate voltage on each string (as shown in the next figure) and therefore optimizes system efficiency and lowers the overall system power consumption.

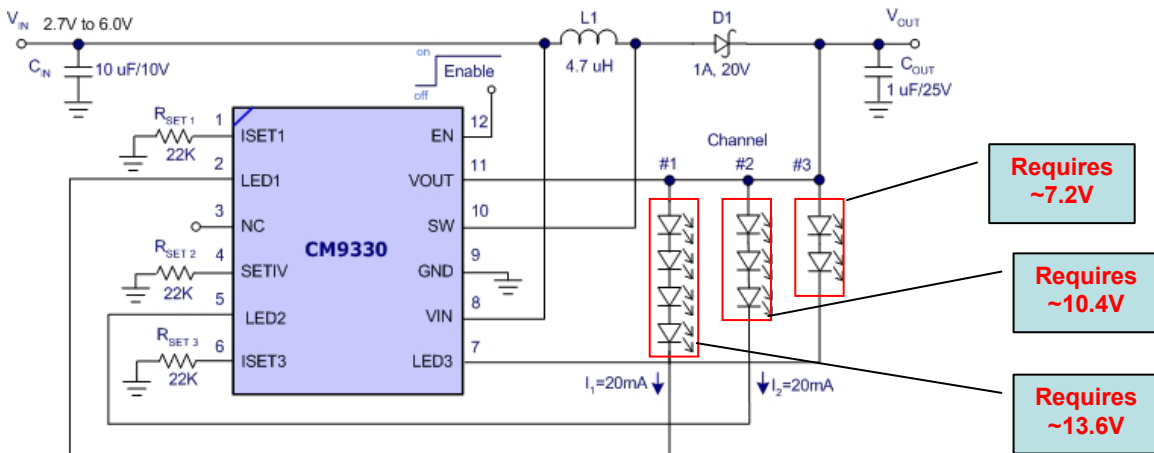

Technical Overview

The Battle for Matching and Efficiency

In order to provide uniform brightness of a display, the LEDs should be fed with the same current. That is why a common way of driving backlight LEDs consists of stacking them in series. As a result the same current will flow through the string and the matching is inherent. Unlike for current regulated architectures, matching is therefore not an issue any longer. Simply a high voltage design is required to be able to supply several LEDs in series.

With a fully charged Li-Ion battery, not more than one LED could be fed directly. Therefore, in order to drive a string of LEDs a boost circuit is required.

In addition, it is common to drive several LED sub-systems from a single driver in order to optimize space. For instance, main display, sub-display, camera flash and indicator LEDs can be driven from the same part. Such a configuration might require different number of LEDs per string. An LED is indeed a diode with a threshold voltage of 3.3v. Each LED needs to be fed with a little bit more than 3.3v. If there are 4 LEDs in series the required voltage to make them light is $4 \times 3.3v = 13.2v$.

For three strings (which is a common application for handset equipment) with 2,3 and 4 LEDs respectively per string, the designer needs 6.6v, 9.9v and 13.2v to make them work. However, designers cannot afford to allocate one boost circuitry for each string. With a single boost for 13.2v, all strings would work, but it would be far from optimized. FlexBoost™ patented technology from California Micro Devices address the asymmetrical configurations in the most efficient way.

FlexBoost™ Technology

Fig.1 shows the architecture of FlexBoost™ technology in a case study of 5+4+2 WLED's per strings. Each of the three strings is connected on top to the same power line (out of the boost circuit). An NMOS driver is connected at the bottom. A current regulator drives each NMOS.

An internal pulse circuit generates 1/3 duty cycle signals, shifted each other with 1/3 of the period. En1, En2, En3 are such signals. They turn the current regulator ON/OFF of each string with the rate 1/3. As a result, just one string at a time is supplied by the boost circuit with the current $I_{led_peak} = 3 \times I_{led}$.

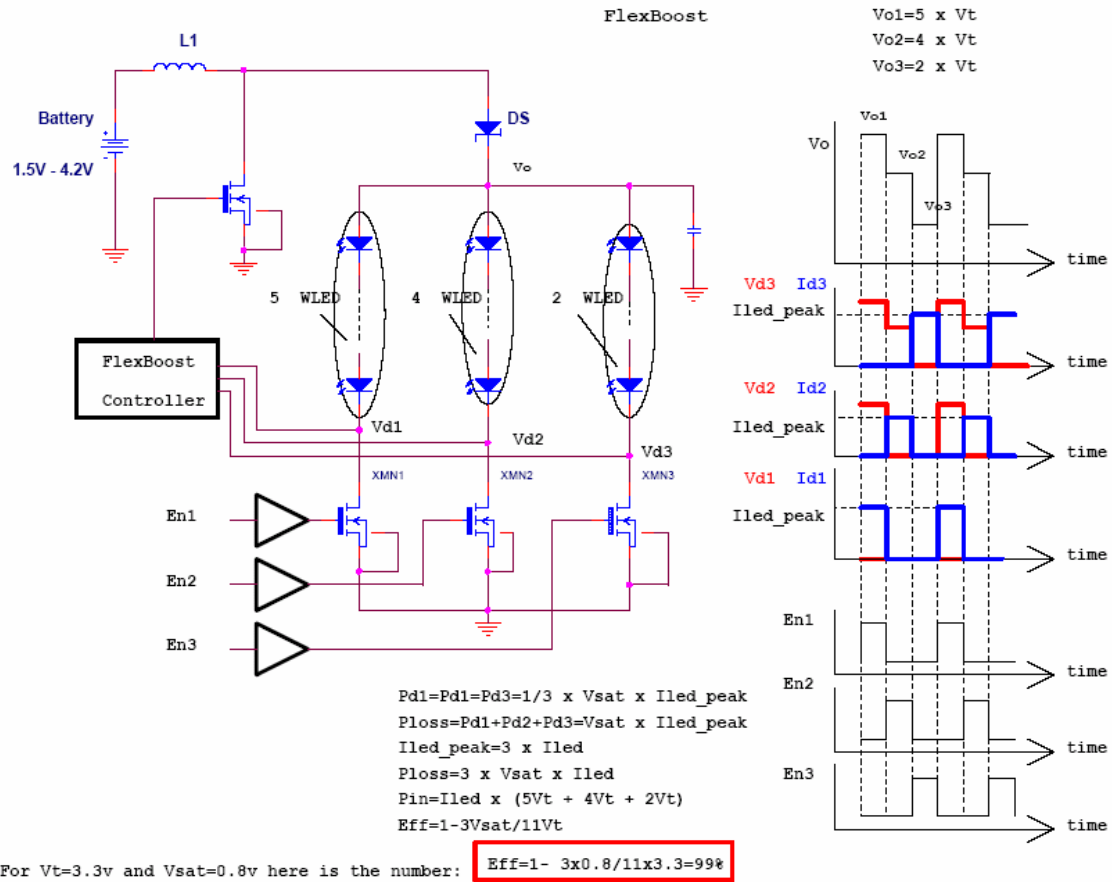

Fig.1

We should compare pulse mode function with continuous function of the regular application. So, a 1/3 duty pulse current (I_{led_peak}) is equivalent to three times the continuous current (I_{led}).

When ON, the drain voltage of each NMOS is $V_{sat} = 0.8v$. When OFF, the drain voltage jumps to the boost voltage.

The major piece of the FlexBoost™ engine is the FlexBoost™ Controller. It checks constantly drain voltages V_{d1}, V_{d2}, V_{d3} and keep each at a time at $V_{sat} = 0.8v$.

This way, the boost never exceeds the necessary voltage to supply the string of WLEDs, no matter how many there are. Practically there is no power loss on NMOS drivers. Even the current is three times the I_{led} , it last only a 1/3 of cycle time.

The efficiency, calculated with the assumption that there are no losses on the boost itself, indicates an almost ideal value, limited just by saturation voltage of the NMOS.

The diagrams and formulae from Fig.1 are self-explanatory.

Here are the efficiency formulas for 2 and 3 strings respectively:

$$Eff_{2sF} = 1 - \frac{2}{N_1 + N_2} \times \frac{V_{sat}}{V_t}$$

$$\text{Eff}_{3sF} = 1 - \frac{3}{N_1 + N_2 + N_3} \times \frac{V_{\text{sat}}}{V_t}$$

Traditional Boost Technology

Fig.2 illustrates a similar case study (5+4+2 WLEDs), but using a traditional boost architecture. There is no pulse mode function of the strings, and the boost level is constant and reaches the voltage required by highest # of WLEDs per string (5 in our case study).

The diagrams and formulae are provided with the block diagram. The current of the boost is constant and equal to $3 \times I_{\text{led}}$.

The efficiency, calculated with the same assumption that there are no losses on the boost itself, indicates a theoretical level of 73%.

It is interesting to prove the general formula for N_1, N_2 and N_3 WLEDs per string.

Here are efficiency formulas for 2 and respectively 3 strings:

$$\text{Eff}_{2s} = 1 - \frac{1}{N_1} \times \frac{V_{\text{sat}}}{V_t} - \frac{N_1 - N_2}{2N_1}$$

$$\text{Eff}_{3s} = 1 - \frac{1}{N_1} \times \frac{V_{\text{sat}}}{V_t} - \frac{2N_1 - N_2 - N_3}{3N_1}$$

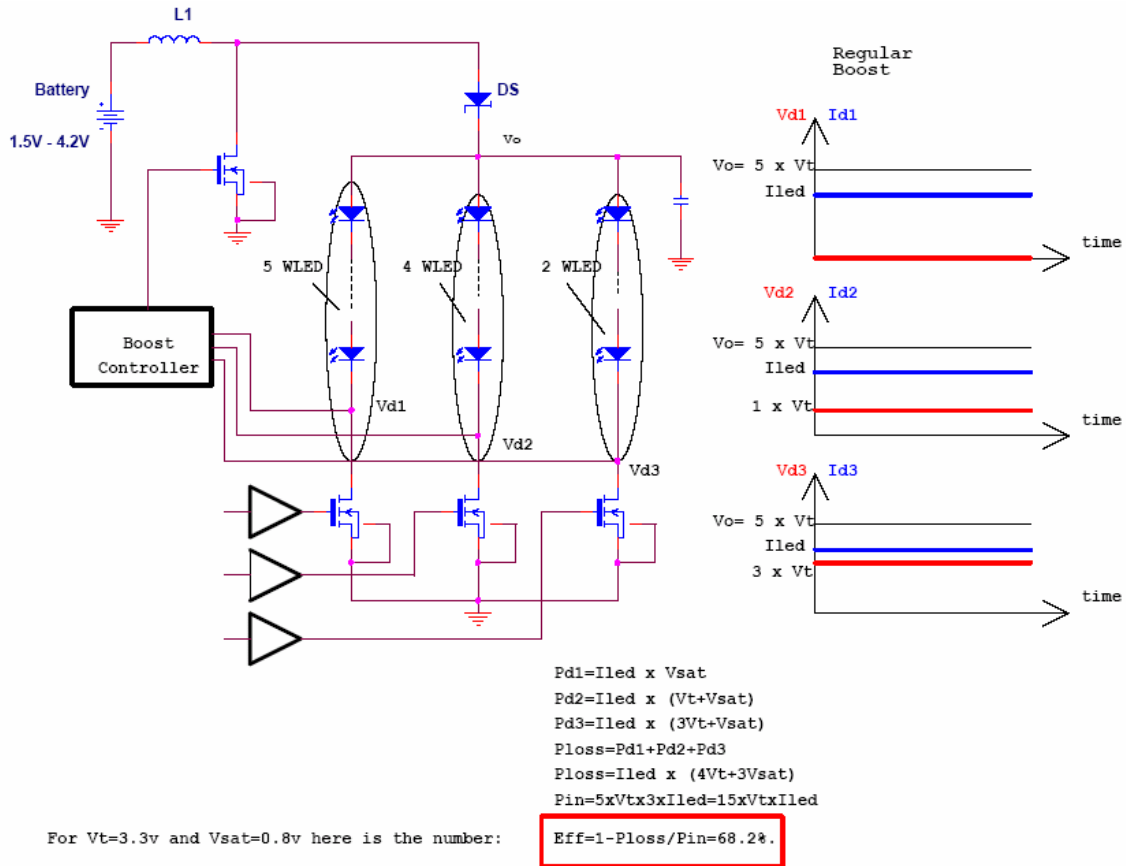

Fig.2

FlexBoost™ Benefits

FlexBoost™ technology basically keeps the same current supply when compared to traditional boost architectures. The breakthrough comes from the fact that its adaptive boost controller adjusts the output voltages to exactly meet each string's requirement. This is a tremendous benefit in terms of efficiency and therefore power savings.

In order to experimentally check the benefit of the new architecture, we have created a special evaluation kit and package for the PhotonIC™ CM9330.

Fig.3 shows the schematics of such a FlexBoost™ based application.

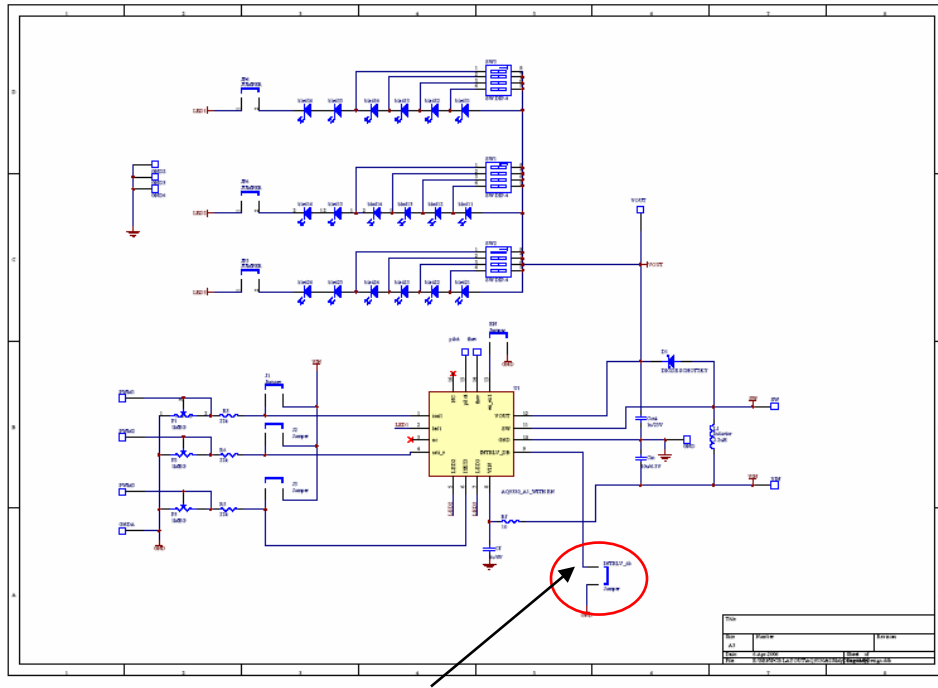

Connected to GND- Regular Boost
 Keeping floating- FlexBoost™.

Fig.3

By using the previous formulas, it is easy to calculate the difference in efficiency between FlexBoost™ and traditional boost topology in the two study cases (2 and 3 strings):

$$Eff_{2sF} - Eff_{2s} = \frac{N1 - N2}{N1} \times \left(\frac{1}{2} - \frac{1}{N1 + N2} \times \frac{V_{sat}}{V_t} \right)$$

$$Eff_{3sF} - Eff_{3s} = \frac{2 N1 - N2 - N3}{N1} \times \left(\frac{1}{3} - \frac{1}{N1 + N2 + N3} \times \frac{V_{sat}}{V_t} \right)$$

In these formulas, N1 is the maximum number of WLEDs per string. One obvious conclusion is that the higher the asymmetry between channels, the higher the benefits in terms efficiency provided by FlexBoost™.

Fig.4: PCB kit used to demo the benefits of FlexBoost™ architecture.

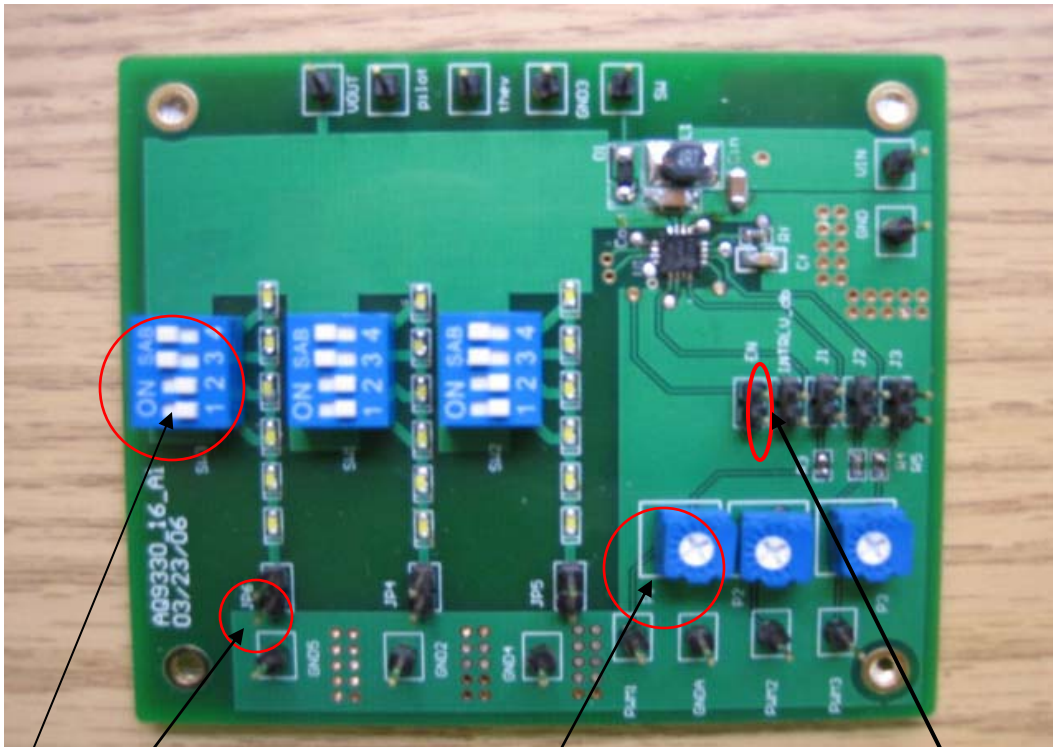

Select the string LEDs configuration

Connect the Amp. meter

Jumper used to demo FlexBoost™ efficiency versus Traditional Boost.

Potentiometer to adjust LED Current.

Fig.4

How to use the CM9330 demo board:

- Choose a certain WLEDs configuration per strings by using SW1, SW2, and SW3 to select the number of WLED per string.
- Connect in series with each string a current meter to read the LED current. Use jumper J4,J5,J6 for this.
- Use potentiometers P1, P2, P3 to adjust the current required by each string.
- Read Input current into the board for FlexBoost™ configuration (Jumper Interlv_db kept floating).
- Put Interlv_db jumper to GND (Regular Boost) and read again the input current.

Fig.5 is a diagram of power input for FlexBoost™ architecture.

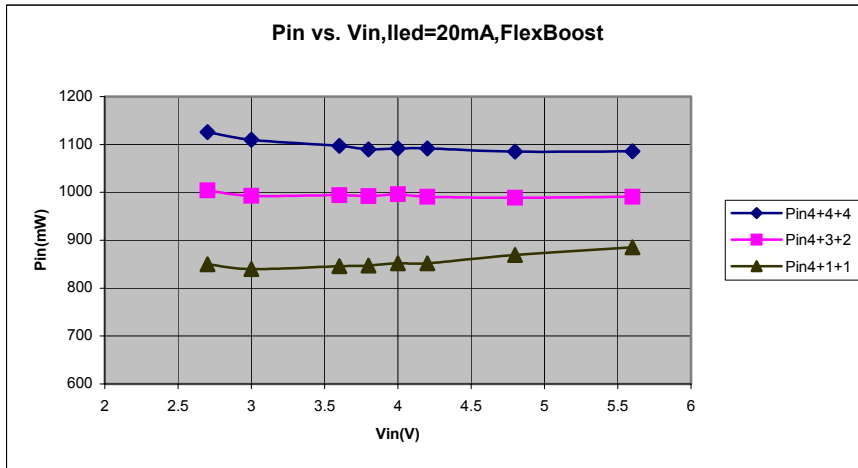

Fig.5

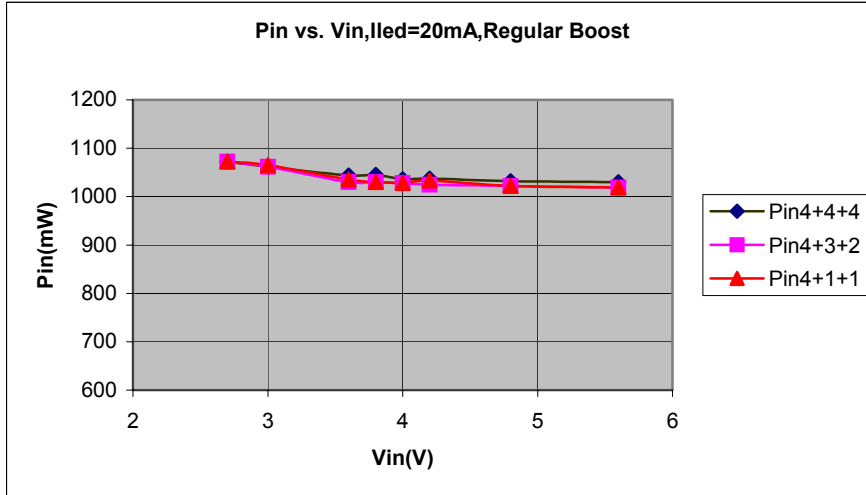

Fig.6

Fig.6. presents the results of the experiment for regular boost application. There are two major features to notice here:

Using traditional boost, the input power (current) is the same no matter the strings configurations.

Using FlexBoost™ topology, the input power (current) strongly depends upon string configuration.

Because there is a current regulator application, output power is the same in both cases ($\# V_t \times I_{led}$). So, input current is a clear mirror of efficiency. In order to compare efficiency in the two cases, we just need to compare input current. For extreme asymmetric configurations, 4+1+1, there is a 15%-20% less input current with FlexBoost™ topology (Fig.4,5).

Results & Conclusion

The following table summarizes results and highlights the tremendous benefit of FlexBoost™ for various asymmetrical configurations:

Configurations	FlexBoost™ efficiency	Standard Boost efficiency	Difference
4WLED+1WLED	97%	56%	41%
4WLED+2WLED	92%	69%	23%
4WLED+3WLED	93%	81%	12%
5WLED+1WLED	92%	55%	37%
5WLED+2WLED	93%	65%	28%
5WLED+3WLED	94%	75%	19%

FlexBoost™ is a unique architecture that is now available to wireless handset designers who plan on driving several (most likely) asymmetrical strings of LEDs off a single chip solution using a single inductor.

California Micro Devices offers a comprehensive product portfolio based on FlexBoost™ architecture including:

- CM9330: 3 strings of LEDs

- CM9320: 2 strings of LEDs

- CM9321: 2 strings of LEDs + dedicated output for OLED

- CM9311: 1 string of LED + dedicated output for OLED